

ASAHI
PENTAX

auto **110** SYSTEM

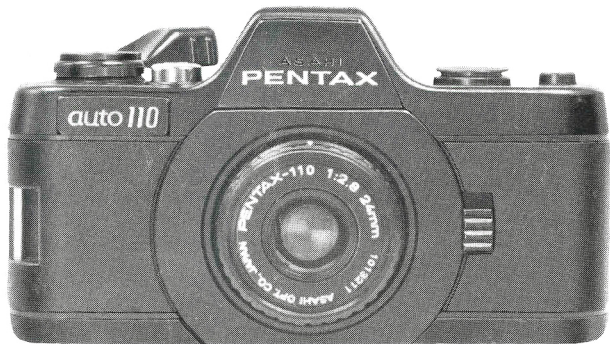

THE PENTAX AUTO 110 SYSTEM

The Pentax AUTO 110 is a fully automatic SLR (single-lens reflex) camera designed along the lines of the popular 35mm SLR. Fully pocketable with the standard lens attached, the AUTO 110 combines the compactness and easy cartridge loading of the 110 film format with many of the systems advantages and the versatility of the latest 35mm SLR cameras. The variety of system accessories available include the battery-powered 110 Winder, the AF 130P Auto Flash, interchangeable lenses, close-up attachment lenses, filters and other special purpose attachments. In addition to the Pentax-110 24mm f/2.8 standard lens, interchangeable lenses available include the Pentax-110 18mm f/2.8 wide-angle lens (approx. equal to a *35mm* wide-angle in the 35mm format) and the Pentax-110 50mm f/2.8 telephoto (approx. equal to a *100mm* telephoto in the 35mm format). Close-up lenses include S31 and S16 for the standard lens; W21 for the wide-angle; T26 and T43 for the telephoto; UV and skylight filters are also available for the standard and wide-angle lenses. Other accessories include assorted cases for the camera and attachments, individual lens hoods, lens caps, body cap, a special tripod adaptor and eyesight correction lenses.

Appearing as the world's smallest and lightest SLR, the Pentax AUTO 110 welcomes you to its world of *pocketable pleasure*.

CONTENTS

PENTAX AUTO 110

Specifications	2
Description of parts	4
Battery loading	6
Film loading	8
Focusing	9
Basic shooting instructions	10
Lens changing	12

110 WINDER

Description of parts	14
Specifications	15
Battery loading.....	16
Attaching the winder	18
Film advance	19
Shooting	20
After shooting · using a tripod	21

AF 130P AUTO FLASH

When to use flash	23
Description of parts	24
Specifications	25
Battery loading	26
Mounting the flash unit	27
Shooting	28
Test flash	29
Effective flash range.....	30
Flash synchronization · Exposure	31
WARRANTY POLICY	32

AUTO 110 SPECIFICATIONS

- Type** ————— TTL metering 110 SLR camera with bayonet mount for interchangeable lenses.
- Film Type** ————— Cartridge-loading 110 film.
- Negative Format** ————— 13mm x 17mm.
- Lens** ————— Pentax-110 24mm f/2.8; 47-degree angle of view; 25.5mm filter threads. Focusing Range: 0.35m—∞.
- Lens Mount** ————— 110 bayonet mount; 80-degree setting angle; features shutter lock provision.
- Viewfinder** ————— Eye-level pentaprism finder with quick-return mirror.
- Focusing** ————— Central split-image focusing spot surrounded by matte field.
- Viewfinder Information** — Green LED indicates adequate shutter speed (minimum of 1/30 sec. at f/2.8); yellow LED indicates slow shutter speed (less than 1/30 sec.) requiring use of tripod or auto flash to avoid camera shake.
Magnification: 0.75X showing 87% of the picture area.
- Battery Check** ————— Viewfinder LEDs fail to light on depressing shutter button when batteries are low.
- Exposure Metering** ————— Center-weighted, TTL metering at full aperture via SPD cell. EV Range: 3 - 17 (24mm f/2.8 lens; ASA 100).

Film Speed Setting	Automatic set for available 110 films.
Shutter	Programmed electronic behind-the-lens shutter.
Shutter-Speed/ Aperture Range	1/750 sec. at f/13.5 - 1 sec. at f/2.8.
Film Advance	Two 145-degree strokes of film advance lever advance film a single frame; 60-degree pre-advance setting.
Exposure Count	Frame number appears in back cover window.
Other Features	Synch terminal for automatic flash synch with AF130P auto flash unit at 1/30 sec. (f/2.8); tripod socket, lens release button, wrist strap hook, battery holder tray; winder capability.
Power Source	Two 1.5V silver-oxide batteries (G 13).
Size	With Standard Lens: 56mm x 99mm x 45mm (2.2" x 3.9" x 1.8") Body Without Lens: 56mm x 99mm x 32mm (2.2" x 3.9" x 1.3")
Weight	With Lens: 172 grams (6.1 ozs.) Body Only: 159 grams (5.6 ozs.)

AUTO 110 DESCRIPTION OF PARTS



1. 110-Bayonet Mount
2. Aperture diaphragm
3. Shutter release button
4. Film advance lever
5. Lens release button
6. Flash synch-shoe
7. Flash contact pin
8. Wrist strap hook
9. Lens distance scale
10. Distance scale index
11. Focusing ring
12. Shutter/mirror box module
13. Viewfinder eyepiece
14. Film cartridge chamber
15. Battery chamber
16. Battery holder tray
17. Back cover window
18. Winder contact terminals
19. Back cover lock
20. Film cartridge chamber
21. Film drive coupler
22. Tripod socket

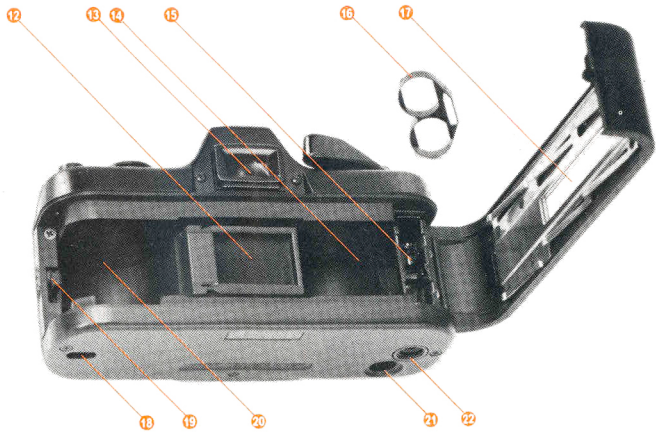

BATTERY LOADING

- 1 Depress the back cover lock, open the back cover and remove the battery holder tray from inside the battery chamber.
- 2 Insert the (-) side of one of the batteries into the opened side of the tray. Then, turn the tray over and do the same

with the other battery. The (-) side of both batteries will correspond with the (-) indication on top of the tray when inserted properly.

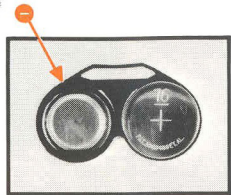
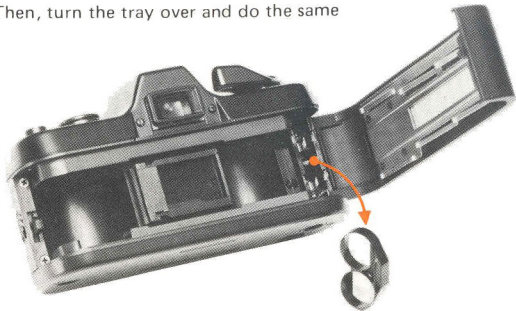

3 Insert the loaded tray — curved-side first— back into the battery chamber. Proper contact will be made no matter which battery is on top as long as batteries have been inserted into the tray properly.

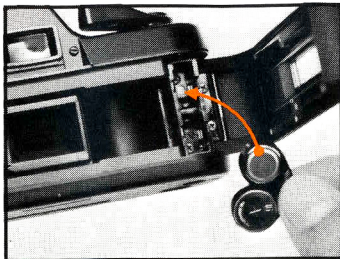

Battery Check Under normal usage, one set of batteries will last approximately one year or operate the electronic shutter approximately 10,000 times. If batteries are inserted improperly, or if they have become worn, the LED indicator lamps in the viewfinder will fail to light when you depress the shutter release. If batteries are worn, replace both with G 13 silver oxide batteries (Eveready S76E or equivalent).

FILM LOADING

The Pentax AUTO 110 automatically preselects the film speed for both ASA 100 and ASA 400 films; no film speed setting is required.

- 1 Insert the film cartridge as illustrated.
- 2 Close the Back Cover.

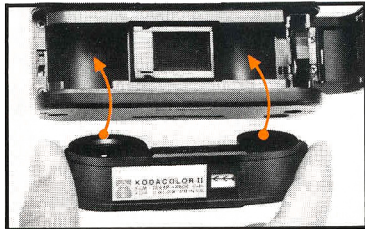

3 Turn the Film advance lever about 7 times until the numeral "1" appears in the back cover window. You are now ready to take your first picture.

* When using the 110 Winder to advance the film, refer to "Film Advance" of the 110 Winder section of these instructions (page 19).

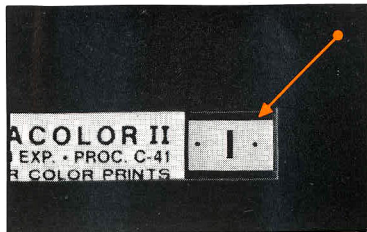

FOCUSING

Look through the viewfinder eyepiece and turn the focusing ring of the lens to bring the image into focus. Reasonably sharp focus can be obtained by focusing on any part of the focusing screen. To be assured of pinpoint focusing, however, check your focus against the spot in the center of the screen. If the image is completely intact, focus is precise. If the image is split or broken, however, adjust the focusing ring further until both halves of the image fit together perfectly.

• For those who find focusing difficult with the split-image screen because of poor eyesight, etc., eyesight correction lenses (covering a range from -5 to +3 diopters) are available as accessories for the AUTO 110.

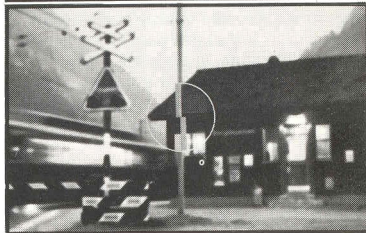
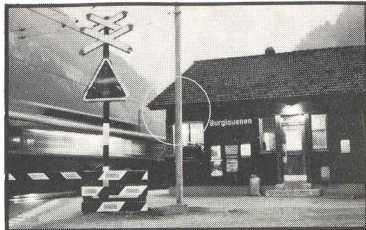

BASIC SHOOTING INSTRUCTIONS

Before Shooting

1 Depress the shutter release button halfway. Either a green or a yellow diode light will come on inside the viewfinder. If the green light-emitting diode (or LED) lights, correct exposure will be obtained without use of flash or a tripod.

2 If the yellow LED lights, it signifies that light is insufficient to obtain correct exposure unless the accessory electronic flash unit or a tripod is used. (If you use a tripod, fix the tripod to the tripod socket **A** at the base of the camera. For instructions on the use of electronic flash, refer to the "AF 130P Auto Flash" section of this manual.)

Shutter Cocking Turn the film advance lever two full strokes to cock the shutter. The shutter is now ready to release.



Film Advance Each time you recock the shutter after tripping it, the film will advance and the back cover window will register the next number – 2 - 3 - 4 and so forth until the end of the roll.

At the End of the Roll

1 Depending on the film cartridge loaded in the camera, the last exposure will be either "12" or "20". In both cases, an "X" will appear in the window after the last exposure. Continue advancing the film three to four more turns beyond the "X" or until the film ends.

(CAUTION: When the film advance lever no longer advances, you have reached the film end. Stop winding and do not attempt to force the lever to avoid breakage).

2 Open the back cover and remove the film cartridge by turning the camera upside down and tapping lightly.

* Refer to the "110 Winder" section of these instructions when advancing film with the winder.

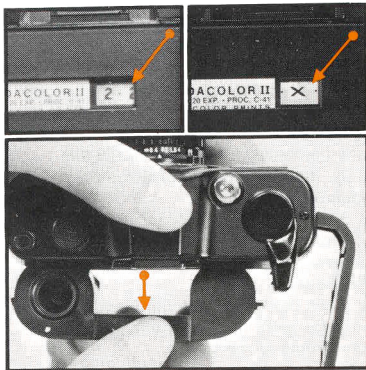

LENS CHANGING

Three interchangeable lenses are available for the AUTO 110 which bayonet into the lens mount at the front of the camera to enable a wide variety of shooting possibilities. In addition to the 24mm f/2.8 standard lens, an 18mm f/2.8 wide-angle lens and a 50mm f/2.8 telephoto lens are available.

Lens Removal Push upwards on the lens release lever and turn the lens approximately 90 degrees to the left until the lens slips out of the mount.

Lens Mounting

- 1 Match up the red distance scale index of the lens **A** with the red dot on the camera body **B** and insert the lens into the body.
- 2 Turn the lens to the right until it locks in place, with the red distance scale index positioned at the top.

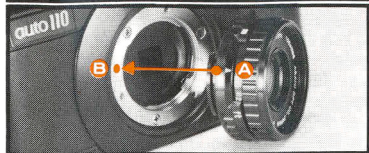
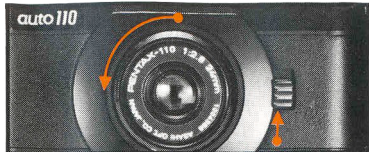



110 WINDER DESCRIPTION OF PARTS

1. Contact pins
2. Power switch
3. Attachment screw
4. Film drive coupler

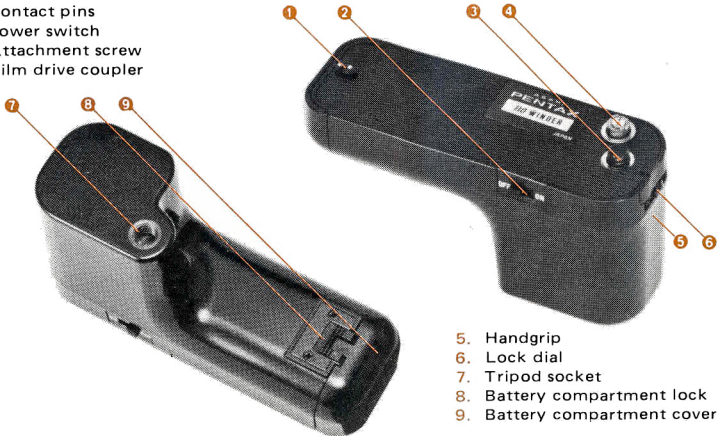

5. Handgrip
6. Lock dial
7. Tripod socket
8. Battery compartment lock
9. Battery compartment cover

PENTAX 110 WINDER SPECIFICATIONS

Type	Battery-Powered Film Winder.
Power Source	Two 1.5V AA-size penlight batteries.
Film Advance Mode	Single-frame operation after shutter release via camera shutter button.
Shutter-Speed	
Synchronization	Operates at all shutter speeds.
Mounting	Mounts to tripod socket at base of camera.
Other Features	Tripod socket, built-in grip, power switch.
Size	52mm x 35mm x 100mm
Weight	112g/4.0ozs. (without batteries)

BATTERY LOADING

- 1 Make sure that the winder power switch is set to OFF.
- 2 Holding the winder upside down, slide the battery compartment lock in the direction of the arrow with your fingernail and lift the cover out with your other hand.
- 3 Insert two AA size penlight batteries in the battery compartment in accordance with the (+) and (-) diagrams inside the compartment.

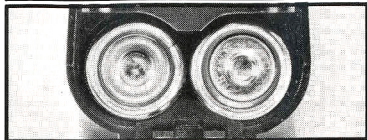
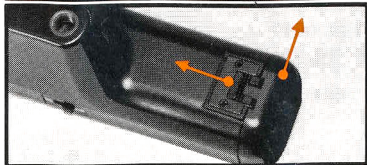
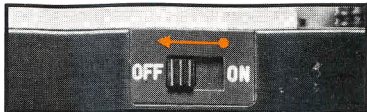

4 Replace the battery compartment cover by sliding the lock all the way back with your fingernail and snapping the cover back into place by inserting the bottom tabs **A** first, and then the top tab **B**. Let go of the lock lever to lock the cover in place.

* **Battery Check** When the film advance speed becomes slow and irregular, it indicates that batteries are worn. Replace both batteries together with high-performance AA-size (penlight) dry-cell batteries or alkaline batteries. Film will not advance if batteries are not inserted properly.

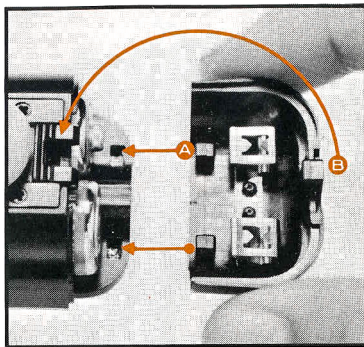

ATTACHING THE WINDER

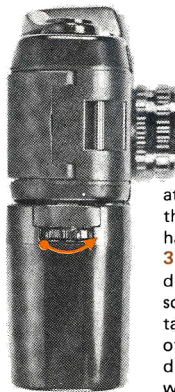
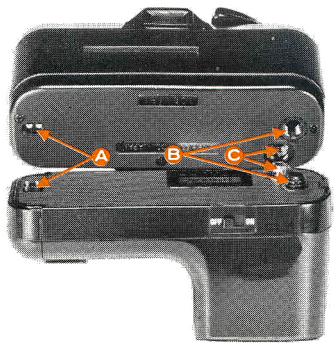

1 Hold the back of camera at a right angle to the winder as illustrated, matching up each of the terminals **A**, **B** and **C** on both the winder and the camera with your eye.

2 Then, turn the camera so that it sets flat atop the winder, making sure that all the contact points have enmeshed properly.

3 Rotate the knurled lock dial on the side of the winder so that the winder screw attaches to the tripod socket of the camera. Tighten the dial firmly to secure the winder in place.

FILM ADVANCE

With new film: After loading a fresh film cartridge into the AUTO 110, turn the winder power switch to ON. The film will advance automatically until the numeral "1" appears in the back cover window. The camera is now ready to shoot.

With a previously loaded film cartridge: If you attach the winder with a partially wound film cartridge already loaded in the camera, the winder will advance the film a single frame if you turn it on while the camera's film advance lever is uncocked. If the film advance lever is cocked when you turn the winder on, film will not advance until after you trip the shutter.



SHOOTING

Bring the camera up to your eye and, after you have focused, press the shutter release to take the picture.

Horizontal shooting posture: Hold the winder and camera firmly as illustrated when shooting horizontally.

Vertical shooting posture: For vertical shooting with the winder, the camera should be braced as illustrated for added support. There is greater tendency for camera movement to occur when shooting vertically. Your pictures will blur if you do not hold the camera firmly as indicated.

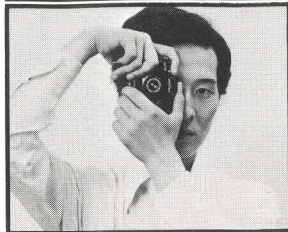

AFTER SHOOTING · USING A TRIPOD

When Finished Shooting

After the last exposure has been made, the film will automatically wind out until the film end and stop. Then, turn the winder power switch to OFF and remove the cartridge.

* Always attach and detach the winder with the power switch set to OFF.

Use of a Tripod

A tripod may be screwed into the tripod socket at the base of the winder grip.

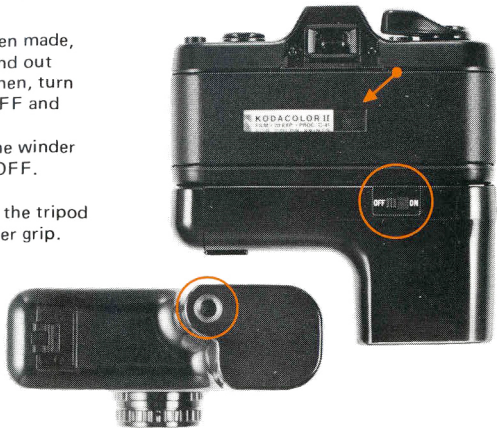



WHEN TO USE THE FLASH

The Pentax AF 130P auto flash unit was designed exclusively for use with the AUTO 110 in situations where lighting is insufficient for correctly exposed photographs. As a rule, use either the AF 130P or a tripod when the yellow indicator in the camera viewfinder lights, indicating a low light reading. These occasions are principally outdoors at night or indoors in dim lighting. Use of flash is required less frequently with high-speed ASA 400 film than with ASA 100.

* Do not use the flash unit when the green LED lights in the finder, in which case over-exposure will result.

AF 130P AUTO FLASH DESCRIPTION OF PARTS

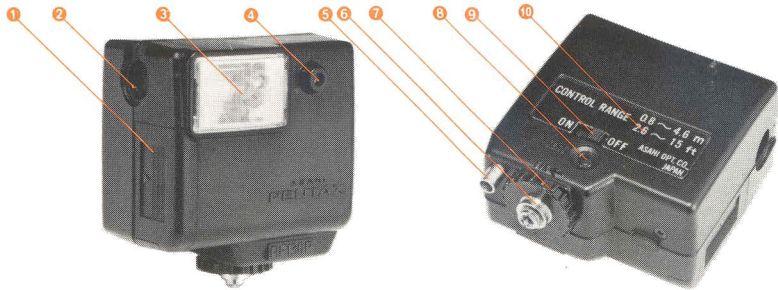

1. Battery compartment cover
2. Flash-synch-cap holder
3. Flash head
4. Auto sensor
5. Contact pin

6. Flash-synch shoe
7. Lock dial
8. Test button/ready lamp
9. Power switch
10. Flash range scale

AF 130P AUTO FLASH SPECIFICATIONS

Type	Direct contact Auto Flash Unit.
Guide Number	13 (ASA 100 in meters).
Effective Flash Range	0.8 - 4.6 meters (2.6 - 15 ft.).
Sensor Reception Angle	Approx. 18 degrees
Number of Flashes	250 (with alkaline-manganese batteries)
Recycling Time	7 sec. (at full charge)
Color Temperature	Equivalent to daylight.
Flash Coverage Angle	45° vertical, 55° horizontal. (sufficient coverage for the 18mm f/2.8 wide-angle lens).
Power Source	Two 1.5V AA-size alkaline-manganese batteries.
Mounting	Mounts to special contact on top of camera.
Synchronization	Automatically synchronizes with programmed shutter at 1/30 sec. at programmed aperture of f/2.8.
Other Features	Combined Test Button/ Ready Lamp; power switch.
Size	71mm x 41mm x 63mm
Weight	102g/3.6 ozs. (without batteries)

BATTERY LOADING

1 Slide the battery compartment cover in the direction of the arrow and remove it.

2 Insert two AA-size penlight batteries into the battery compartment in accordance with (+) and (-) diagrams inside the compartment. Then, replace the cover.

* Do not use Ni-Cd batteries in this unit. For battery replacement, use high-performance AA-size alkaline batteries.

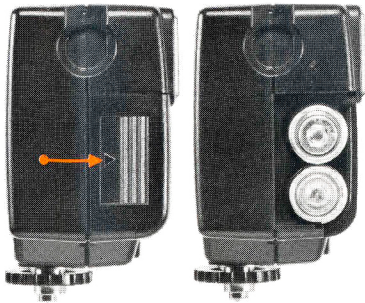

MOUNTING THE FLASH UNIT

Before mounting the flash unit, remove the flash-synch-shoe cap on the camera body and place it in the synch-cap holder on the side of the flash unit to prevent losing it.

1 Hold the camera and the flash unit with their backsides facing you. Then, insert the flash synch contact **A** of the flash unit into the flash-synch-shoe **B** on top of the camera. At the same time, make sure that the small contact pins **C** line up properly for insertion.

2 Secure the flash unit to the camera by turning the knurled lock dial in the direction of the arrow.

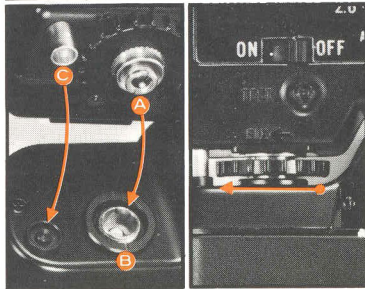
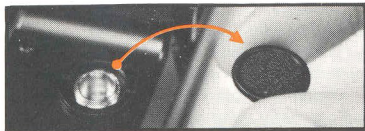

SHOOTING

- 1 Slide the flash unit's power switch to ON. (The flash unit synchronizes automatically with the camera's shutter system when the power is switched on.)
- 2 In approximately 5 to 10 seconds the yellow ready lamp on the back of the flash unit will light to indicate that the unit is fully charged. After ascertaining that the subject is in the effective auto flash range of the unit (See "Effective Flash Range," page 30), focus and shoot in the normal manner with the camera's film advance lever.

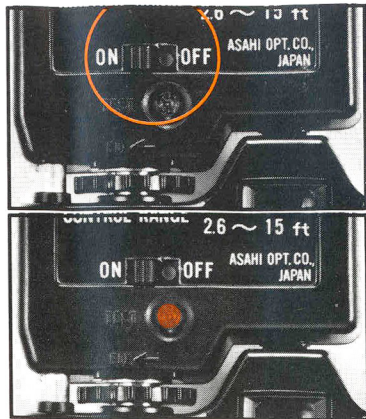

TEST FLASH

Testing the Unit: After inserting new batteries, or when the flash unit has not been used for a long period of time, it is a good idea to test it to assure that it works properly.

- 1 Turn the power switch to ON.
 - 2 When the ready lamp lights (which also doubles as the test button), press it for test flash.
- * Normally the flash unit will flash if it is working properly. The ready lamp will not light and the unit will not flash, however, if batteries are improperly inserted or worn down. If there is a problem, and neither of the above is the cause, the unit may require servicing.

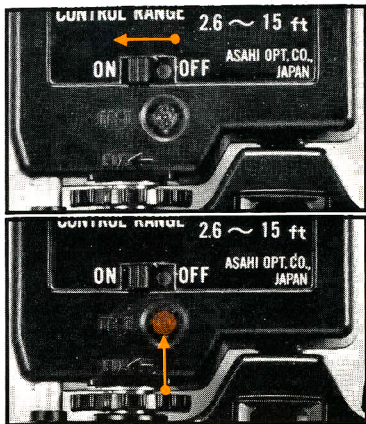

EFFECTIVE FLASH RANGE

The auto flash control range of the AF 130P is 0.8 - 4.6 meters (2.6 - 15 ft.) when using both ASA 100 and ASA 400 film. Underexposure will result if the subject is beyond this range; likewise, overexposure will result if the subject is too close.

* With practice you will be able to easily estimate whether or not the subject is within effective flash range. If you are not sure, the quickest way to find out is to focus with the lens and read off the distance to the subject indicated on the lens' distance scale. Correct focus will be obtained if the subject is within the effective range.

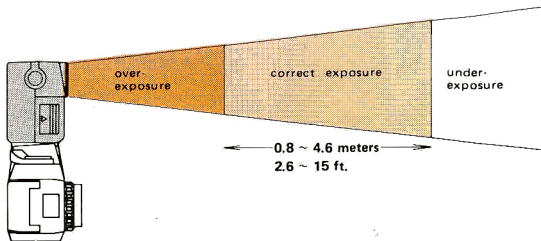

FLASH SYNCHRONIZATION & EXPOSURE

With both ASA 100 and ASA 400 films, the AF 130P synchronizes automatically when the power is switched on (even when the ready lamp is not lit). With ASA 100 film loaded in the camera, the flash unit synchronizes at a shutter speed of 1/30 sec. and a lens aperture of 2.8; with ASA 400 film, shutter speed synchronization is also 1/30 sec., while the preselected lens aperture changes to f/5.6.

* Although there are less occasions when use of the flash unit is necessary with ASA 400 film in the camera, the smaller f/5.6 preselected lens aperture chosen by the camera when ASA 400 film is used offers greater depth of field, or the portion of the distance in front of and behind the subject that is in focus. Thus, ASA 400 film is useful when a wider focus range is desired in flash photography.

WARRANTY POLICY

All Asahi Pentax cameras purchased through authorized bona fide photographic distribution channels are guaranteed against defects of material or workmanship for a period of twelve months from date of purchase. Service will be rendered and defective parts will be replaced without cost to you within that period, provided the equipment has not been abused, altered, or operated contrary to instruction. Because the tolerances, quality, and design compatibility of lenses other than Pentax lenses are beyond our control, damage caused by use of such lenses will not be covered by this warranty policy. The manufacturer or its authorized representatives shall not be liable for any repair or alternations except those made with its written consent and shall not be

liable for damages from delay or loss of use or from other indirect or consequential damages of any kind, whether caused by defective material or workmanship or otherwise; and it is expressly agreed that the liability of the manufacturer or its representatives under all guarantees or warranties, whether expressed or implied, is strictly limited to the replacement of parts as hereinbefore provided.

Procedure During 12-month Warranty Period

Any Asahi Pentax which proves defective during the 12-month warranty period should be returned to the dealer from whom you purchased the equipment or to the manufacturer. If there is no representative of the manufacturer in your country, send the equipment to the manufacturer, with postage prepaid. In this case, it will take a considerable length of time before the equipment can

be returned to you owing to the complicated customs procedures required in Japan in importing and re-exporting photographic equipment. If the equipment is covered by warranty, repairs will be made and parts replaced free of charge, and the equipment will be returned to you upon completion of servicing. If the equipment is not covered by warranty, regular charges of the manufacturer or of its representatives will apply. Shipping charges are to be borne by the owner. If your Asahi Pentax was purchased outside of the country where you wish to have serviced during the warranty period, regular handling and servicing fees may be charged by the manufacturer's representatives in that country. Notwithstanding this, your Asahi Pentax returned to the manufacturer will be serviced free of charge according to this procedure and

warranty policy. In any case, however, shipping charges and customs clearance fees are to be borne by the sender. To prove the date of your purchase when required, please keep the receipts or bills covering the purchase of your equipment for at least a year. Before sending your equipment for servicing, please make sure that you are sending it to the manufacturer's authorized representatives or their accredited repair shops, unless you are sending it directly to the manufacturer. Always obtain a quotation of the service charge, and only after you accept the quoted service charge, instruct the service station to proceed with the servicing.

This warranty policy does not apply to Asahi Pentax cameras purchased in the U.S.A. and U.K. For these cameras, please refer to the separate Warranty Policy Card enclosed here.



Asahi Optical Co., Ltd. C.P.O. 895, Tokyo 100-91, JAPAN

Asahi Optical Europe N.V. Weiveldlaan 3-5, 1930 Zaventem Zuid-7, BELGIUM

Pentax Handelsgesellschaft mbH. 2000 Hamburg 54 (Lokstedt), Grandweg 64, WEST GERMANY

Pentax Corporation 9 Inverness Drive East, Englewood, Colorado 80112, U.S.A.

Pentax of Canada Ltd. 1760 West 3rd Avenue, Vancouver, B.C. V6J 1K5, CANADA

Pentax U.K. Ltd. Pentax House, South Hill Avenue, South Harrow, Middlesex HA2 OLT, U.K.

Asahi Optical Brasileira Ind. e Com. Ltda. Rua Estados Unidos, 1053, São Paulo-SP, BRASIL

Printed in Japan